

混合式步进电机规格书

HYBRID STEPPING MOTOR SPECIFICATION

外形图 (DIMENSIONS) unit=mm

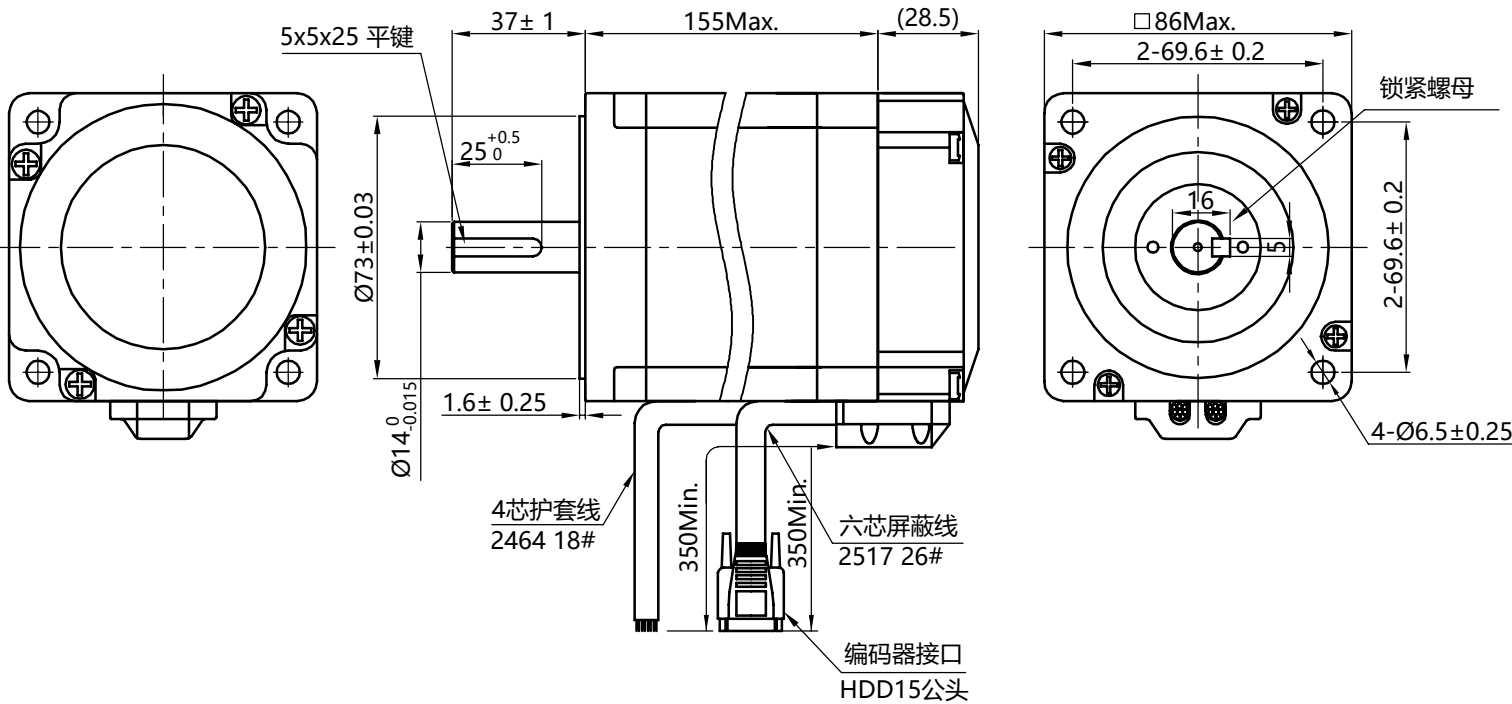

电气原理图

Wiring Diagram

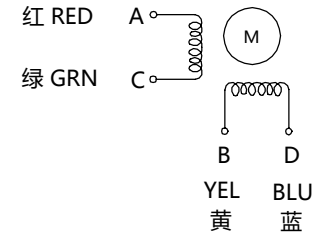

励磁顺序 vs. 旋转方向

Exciting Sequence vs.

Direction of Rotation

STEP	A	B	C	D	
1	+	+	-	-	CCW ↑
2	-	+	+	-	
3	-	-	+	+	
4	+	-	-	+	

CW
↓

从安装面看为顺时针方向

Clockwise view from mounting side

编码器连接器引线颜色

Encoder Wiring Diagram

EA+	Encoder A phase input+	BLACK 黑
EA-	Encoder A phase input-	BLUE 蓝
EB+	Encoder B phase input+	YELLOW 黄
EB-	Encoder B phase input-	GREEN 绿
Vcc	Encoder Voltage(+5V)	RED 红
EGND	Encoder Grand(0V)	WHITE 白

1、相数 Number of Phase	2	注: 1.电机装1000线编码器 2.锁紧螺母用680胶水粘死。	版本 REV.	变更内容 REVISION RECORD	日期 DATE	
2、步距角 Step Angle	1.8° deg.		设计 DESIGN	Changzhou BesFoc Motor Co., Ltd		
3、额定电压 Rated Voltage	2.64 V		标准化 STANDARD	www.besfoc.com		
4、额定电流/相 Rated Current/Phase	6 A (峰值 Peak Value)		工艺 TECHNOLOGY	规格书 Specification		
5、相电阻 Phase Resistance	0.44 Ω ± 0.1(20°C)		审核 CHECK			
6、相电感 Phase Inductance	3.8 mH± 20%(1kHz 1V RMS)		批准 APPROVE			
7、保持力矩 Holding Torque	12 N.m			品名 TITLE	步进电机 STEPPING MOTOR	
8、绝缘等级 Insulation Class	B (130°) 温升 80K Max.			图号 DWG.NO.	BF86HSN120	
9、重量 Weight	5.6 kg			材料 MATERIAL		SIZE A4
规格 Specifications		备注 Comment	版本 REV.	A	比例 SCALE 1:2	页 SHEET 1 of 1